

EXPOSURE GLASS

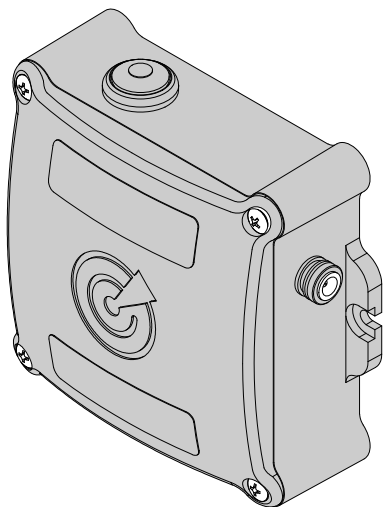

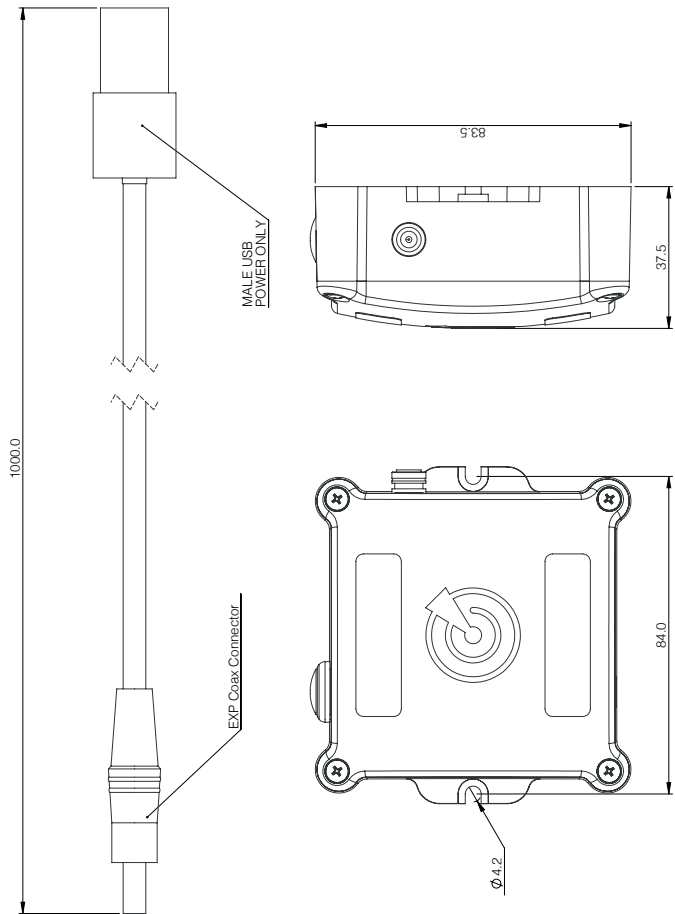

All dimensions are in mm

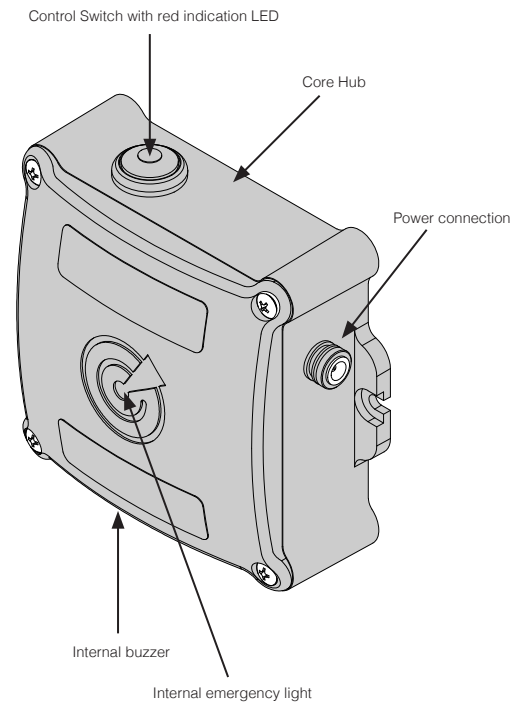

OLAS TRANSMITTERS

The OLAS T2, OLAS Tag and OLAS FLOAT-ON are considered OLAS transmitters. They emit a Bluetooth signal which is monitored by the OLAS receivers.

OLAS RECEIVERS

The OLAS receivers track the OLAS transmitters. OLAS receivers are:

1. Guardian
2. OLAS N2K
3. Core
4. OLAS Mobile application
5. Extender - This operates as a repeater to increase the range of the OLAS N2K, Guardian and Core

OLAS MOBILE APPLICATION

The OLAS mobile application allows the OLAS transmitters to be used as a MOB/proximity alarm if used solely with OLAS transmitters. When an OLAS transmitter goes out of range an alarm is set off and overboard screens are activated.

When the OLAS mobile application is connected to the OLAS N2K, Guardian or Core it allows greater control over the OLAS transmitters that are being tracked.

For iOS search for 'OLAS: Wireless Marine Safety' on the App Store.

For Android search for 'Exposure OLAS – MOB Alert' on the Google Play Store.

IMPORTANT INFORMATION

The Core has been designed for recreational marine use. The design conforms to appropriate Electromagnetic Compatibility (EMC) regulations but for optimal performance correct installation is required. For optimum performance the mobile device and the Core should be located at least 0.5 metres from any equipment transmitting or cables carrying radio signals including VHF Radios, antennas and cables.

QUICK START GUIDE

1. Check all OLAS transmitters are switched OFF.
2. Turn on power to the Core or press the control switch once if power has already been connected.
3. If there are no OLAS transmitters in range the Core hub will beep every minute and the switch will flash red.
Note: if the control switch illuminates solid red and the Core hub beeps twice it means an OLAS transmitter is switched on and has been automatically tracked, skip to point 5.
4. Switch on any OLAS transmitters and bring them within 1 metre of the Core hub. The Core will beep twice and the control switch will flash twice each time a transmitter is tracked. If you do not hear the double beep move the transmitter closer to the Core.

After the double beep on the Core the switch will illuminate red. The system is now operational and the OLAS transmitter/s are being tracked.

5. Download the OLAS mobile application and check battery status of all OLAS tags.
6. **WARNING:** Always check the battery of any OLAS transmitter before leaving the dock. If a transmitter battery runs out whilst being used in the system it will cause the alarm to sound.
7. **CHECK BEFORE FIRST USE** - Place the OLAS transmitter at least 4 inches into open water (a cup or bucket will not be enough!)

8. The alarm will sound.
9. Press the control switch once to Pause the alarm .
10. Bring the OLAS transmitter back within 1 metre and press the switch once to reconnect.
11. The Core can be switched off at any point by pressing the control switch for 4 seconds or when the power is disconnected.

CORE FUNCTIONS

There are 2 operating states which can be applied to individual OLAS Transmitters using the OLAS mobile app:

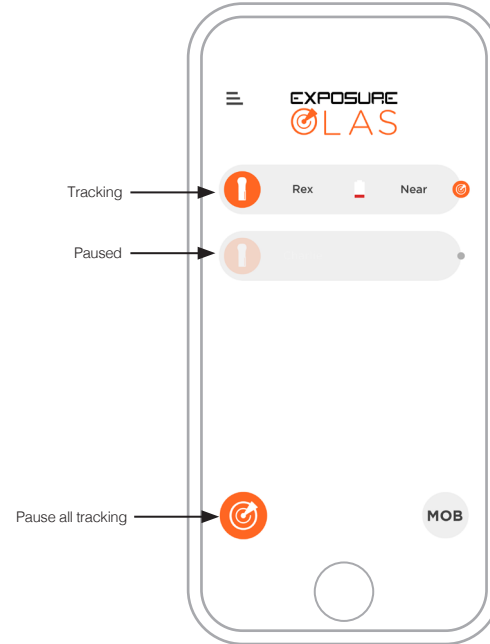

a. Alert

When an OLAS transmitter goes out of range, within 4 seconds the Core will sound its internal alert and trigger the MOB alert on the OLAS App.

b. Paused

Pause state should be used when the user knows an OLAS transmitter will go out of range and they do not want the Core to react i.e. leaving the boat for an extended period or swimming.

OPERATION MANUAL

Index

1. Start up or returning to the vessel
2. No OLAS transmitter Warning
3. Tracking a new OLAS transmitter
4. Tracking a previously tracked OLAS transmitter
5. Tracking an OLAS transmitter using the OLAS mobile app
6. Checking logged OLAS transmitters (without the OLAS mobile app)
7. Checking logged OLAS transmitters (with the OLAS mobile app)
8. OLAS Mobile app features (basic)
9. Pause Tracking
10. Switching OFF the Core
11. Stop tracking an OLAS transmitter (without the OLAS mobile app)
12. Stop tracking an OLAS transmitter (with the OLAS mobile app)
13. Low battery alert
14. OLAS Mobile app features (advanced)
 - a. Detection timing
 - b. Alert delay
 - c. Solo Mode
 - d. Overboard recovery aids
15. Limitations

1. START UP OR RETURNING TO THE VESSEL

- Switch the vessels batteries ON, or press the control switch once.
- The Core will beep once to indicate switching ON.

2. NO OLAS TRANSMITTER WARNING

- If there are no OLAS transmitters in range the Core hub will beep every minute and the control switch will flash red.
- After the first minute it will beep eight times. Thereafter every minute the number of beeps will increase by two until the Core is beeping continuously.
- To move to tracking state an OLAS transmitter needs to be switched on and moved into range.

3. TRACKING A NEW OLAS TRANSMITTER

- To track a new OLAS transmitter it needs to be switched on and brought into 'Close' range of the Core hub. This is around 1 metre. If it is not automatically tracked move it closer to the Core hub.
- Once the OLAS transmitter is automatically tracked the Core hub will beep twice.

4. TRACKING A PREVIOUSLY TRACKED OLAS TRANSMITTER

- To track a previously tracked OLAS transmitter it needs to be switched on and brought into 'Near' proximity which is around 3 metres away. If it is not automatically tracked move it closer to the Core hub.
- When the OLAS transmitter is automatically tracked the Core hub will beep twice.

5. TRACKING AN OLAS TRANSMITTER USING THE OLAS MOBILE APP

- Connect the OLAS mobile app to the Core.
- Navigate to the home screen.
- Any non-tracked OLAS transmitters within range of the Core will appear on the home screen greyed out.
- Click on the right-hand side of the tag and select track.
- The Core hub will beep twice to indicate a tag has been tracked.

6. CHECKING LOGGED OLAS TRANSMITTERS (without the OLAS mobile app)

- Press the control switch once.
- The number of tracked OLAS transmitters is indicated with a single beep sound signal and one red flash per transmitter. Up to 25 transmitters can be tracked.

7. CHECKING LOGGED OLAS TRANSMITTERS (with the OLAS mobile app)

- Open the OLAS mobile app.
- Select the Core from the device selection page.
- All OLAS transmitters that are being tracked will be indicated on the home page.
- Use the homepage to check the battery life of the OLAS transmitters.

8. OLAS MOBILE APP FEATURES (basic)

- Customise the OLAS transmitters name.
- Check OLAS tags battery status.
- Pause OLAS transmitters.
- Pause all tracking.

9. PAUSE TRACKING

1. Press the control switch for 2 seconds, release the control switch after a single beep.
2. When in Paused state the control switch will flash red for 3 seconds ON/ 3 seconds OFF followed by a single beep sound signal.
3. Press the control switch once to restart tracking.

NOTE: if you have removed an OLAS transmitter whilst the Core is in paused state it will beep 3 times and remain in the Paused state.

10. SWITCHING OFF THE CORE

- The Core can be switched off at any point by pressing the control switch for 4 seconds.
- The control switch will illuminate red with a long beep before switching off.

11. STOP TRACKING AN OLAS TRANSMITTER (without the OLAS mobile app)

- To remove any OLAS transmitter without using the OLAS app the Core will need to be switched off.
- Once the Core is switched off, switch off the transmitters you wish to stop tracking. The Core will 'forget' these devices.
- Switch the Core back on and it will track those OLAS transmitters that are still switched on and within range.

12. STOP TRACKING OLAS TRANSMITTER (with the OLAS mobile app)

- Open the OLAS mobile app.
- Select the Core from the device selection page.
- All OLAS transmitters that are being tracked will be indicated on the home page.
- Click on the right hand of the OLAS transmitter box to cycle it through the different operating states. Once it is in Paused state and it appears greyed out then the OLAS transmitter can be switched off and it will be removed from Tracking without activating an alert.

13. LOW BATTERY ALERT

- When an OLAS tags battery level goes below 10% the Core hub will beep once every 5 minutes..
- The alert is indicated by a red flash every 10 seconds on the control switch and the Core Hub.
- The alert will remain until the battery is charged (OLAS T2) or changed (OLAS Tag).
- You can check which OLAS tag has low battery using the OLAS app.
- Once you have located the tag you can:
 - a. Pause the Core, charge or change the battery and restart tracking.
 - b. Switch off the Core, switch off the OLAS tag and then restart the Core.
 - c. Pause the OLAS tag in the OLAS mobile app and then switch off the OLAS tag.

14. OLAS MOBILE APP FEATURES (advanced)

- a. **Detection Time (seconds)** – adjusting the Detection Time allows a period of time where an OLAS transmitter can reconnect silently, preventing any alert from occurring. This may be preferable on larger vessels with multiple cabins where there is an increased chance of signal being blocked.
- b. **Alert Delay (seconds)** – adjusting the alert delay time changes the amount of time the operator has before the MOB alert is activated. This may be preferable on larger vessels where there is increased chance of signal being blocked. During the 'Alert Delay' period the control switch will rapidly flash red. During this period if the control switch is pressed it manually overrides the alarm for 30 seconds allowing the OLAS transmitter to be brought back into range.
 - i. Select the menu tab in the top left-hand corner of the home screen (3 lines).
 - ii. Select 'Alert Settings' Detection time / Alert delay.
 - iii. Use the slider to select the 'Alert Delay' period.
- c. **Solo Mode (minimum 2G connection required)** – designed for boaters operating on inshore waters or on connected vessels. The OLAS mobile app inputs the vessel information manually entered during setup and sends a distress SMS with the vessel name, time, location, and contact number.
 - i. Select the menu tab in the top left-hand corner of the home screen (3 lines).
 - ii. Select 'Solo Mode'.
 - iii. Enter in 'Your Number', this will be sent to your emergency contact so that they can try to make contact after receiving an alert.
 - iv. Enter in your 'Emergency Number', this number will receive your MOB alert and location. You must use your country code prefix e.g. UK(+44) US(+1).
 - v. Select your 'Message Delay' period, this is the amount of time before the MOB alert SMS is sent. A longer period allows more time for self-rescue. A minimum of 1 minute is advised.
 - vi. If a MOB alert message has been sent and the alarm is then manually cancelled an alert cancellation message will be sent.
- d. **Overboard recovery aids** – The GPS location was stored on the OLAS mobile app when the MOB alert occurred.
 - i. Once the vessel is 20 metres away from the MOB alert location an arrow directs back.
 - ii. The second screen shows easy to read GPS coordinates for the alert location and the vessel's current location. This information is requested by the emergency services if a Mayday call is made.
 - iii. On the third screen selecting the phone icon directs the user to call their previously input emergency services number.
 - iv. On the third screen selecting the VHF icon displays the VHF script for a MOB Mayday call with the custom vessel information and alert location automatically input.

17. LIMITATIONS

The connection signal can be blocked by carbon and metal. Operation on carbon or metal boats will require the Core box to be mounted externally.

SOUND AND LIGHT INDICATIONS

OPERATION	ACTION/REACTION
Turning ON	Control switch: Red Box: Low red Buzzer: ON
No OLAS transmitters in range	Control switch: Red flashing Buzzer: 8+ beeps incremental every minute up to 30 minutes
New transmitter tracked	Control switch: Red double flash Buzzer: Double Beep
Checking logged OLAS transmitters	Control switch: Red flash per tracked tag Buzzer: Single beep per tracked tag
Pre alert warning	Control switch: Red Buzzer: Rapid beep
MOB Alert	Control switch: Red constant Box: High red constant Buzzer: Beep every second
System paused	Control switch: Red 3 seconds, off 3 seconds continuous Buzzer: Beep every 6 seconds (if not muted)
Low battery alert <10%	Control switch: Red flash every 10 seconds Box: Red flash every 10 seconds Buzzer: Short beep every 5 minutes

SPECIFICATION

Power/Current	5V/13~17mA
Vessel length	50ft
Connected Transmitters	up to 25
Weight	110 grams
Size	92 x 90 x 38 mm
LED output	55lm
Buzzer output	85db

CORE TROUBLESHOOTING

If you experience a false alarm whilst testing the system, it is likely because the connection between the tag and the Core was broken for longer than 3 seconds. If this occurs carry out the following steps to adjust your system.

1. Accept the alarm with the OLAS App.



2. Bring the tag within 1 metre of the Core.

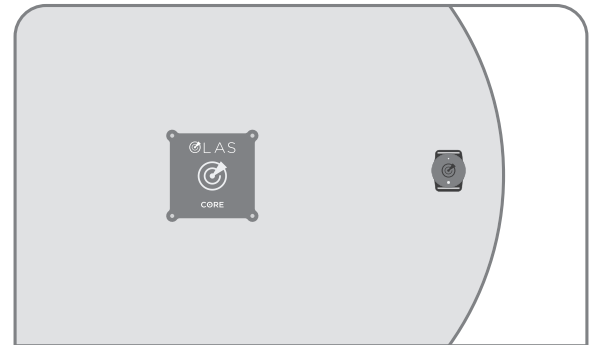

3. Cancel the alarm on the Core by pressing the control switch once. After 10 seconds the system will be tracking again.

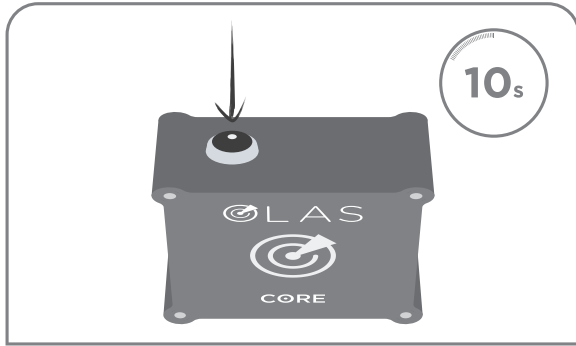

5. Adjust the Alert Delay to 6 seconds. This means if the connection between the tag and the Core is broken for longer than 6 seconds the alarm will sound.

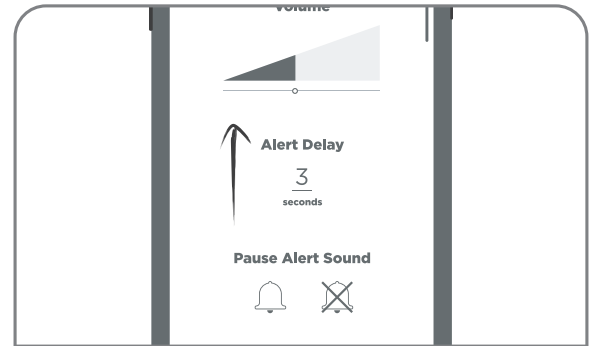

4. Navigate to the Alert Setting



6. Walk to the location where the tag previously set off the alarm and then continue walking around the vessel.

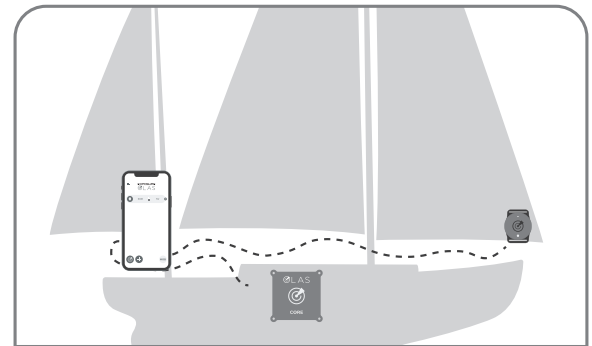

If a false alarm sounds again return to step 1 and increase the Alert Delay at step 5 in increments of 3 seconds.

For further help with setup and trouble shooting visit www.exposure-use.com/Brands/Exposure-OLAS/Product-Support/Troubleshooting-and-Setup

CERTIFICATIONS AND DECLARATIONS

RoHS2 DIRECTIVE 2011/65/EU
(RED) (2014/53/EU)

EN 301 489-1 V2.1.1, EN 301 489-17 V3.1.1, EN 55032:2015
(CSPR 32:2015) and EN 55035: 2017 (CSPR 35: 2016)
EN 300 328 V2.1.1



FCC part 15b CFR47
ICES-003:2012

Contains Transmitter module FCC ID: QOQBG13P
Contains Transmitter module IC: 5123A-BGM13P

WARNING & WARRANTY

Any change or modification to this unit not expressly approved by the party responsible for compliance could void the user's authority to operate the equipment.

This equipment has been tested and found to comply with the limits for a Class B digital device, pursuant to Part 15 of the FCC Rules. These limits are designed to provide reasonable protection against harmful interference in a residential installation. This equipment generates, uses and can radiate radio frequency energy and, if not installed and used in accordance with the instructions, may cause harmful interference to radio Communications. However, there is no guarantee that interference will not occur in a particular installation. If this equipment does cause harmful interference to radio or television reception, which can be determined by turning the equipment off and on, the user is encouraged to try and relocate the module.

This device complies with part 15 of the FCC Rules. Operation is subject to the following two conditions: (1) This device may not cause harmful interference, and (2) this device must accept any interference received, including interference that may cause undesired operation.

Ensure your phone or tablet has maximum volume, charged battery, GPS ON and Bluetooth ON.

Exposure Lights / Ultimate Sports Engineering Ltd. accept no liability for any injuries or other damages arising from the use of their product in any circumstances.

We design them. We make them. We are here to help.
If you are experiencing any problems with your OLAS product or accessories please contact us directly at:
Service: +44 (0)1798 839300 | service@use.group

Alternatively contact your Exposure.OLAS dealer or distributor.
Check web for details www.exposureolas.com

TERMS & CONDITIONS

The OLAS systems are products from Ultimate Sports Engineering Ltd.
OLAS wireless systems utilise OLAS T2 transmitters (OT) and OLAS receivers (OR).
OLAS transmitters consist of the OLAS tag and OLAS Float On.

OLAS receivers include the Core, the Guardian, the OLAS N2K, the Extender and the OLAS mobile application (OLAS app)

Before using any OLAS wireless system it is imperative that you read the DISCLAIMER and the LIMITATION OF LIABILITY which follows. There is legal presumption that by using OLAS wireless systems you have read, understood and accepted the DISCLAIMER and the LIMITATION OF LIABILITY statement.

Setup

Start and setup all OLAS systems before you leave the dock and ensure all OTs are connected. Connecting the OLAS app allows visual indication of connected OTs.

Check the battery level of OLAS tags using the OLAS app. Check the battery level of OLAS Float-On's using the inbuilt colour coded battery indicator.

The OLAS App

Ensure GPS is running in the background on your mobile device. Keep your mobile device plugged in to a charger as GPS drains the battery. It is advised that the app is running in the foreground to enable maximum response time. It can take up to 30 second for the system to respond if the phone is in locked mode.

Test the Connection Whilst In Dock

Test the connection between the OR and the OT by leaving the OR in its planned location and walk the OT to the furthest point on the vessel. Check that all OT's being used are working correctly by submersing them in more the 4 inches of open water which will activate the alarm on the receiver.

Advice

As soon as a MOB situation occurs ensure a crew member keeps visual contact and points at the MOB. Contact the emergency services and give them the co-ordinates from your vessels GPS navigation system and the time since the MOB occurred.

Use OLAS Systems frequently as a practice aid for a MOB situation.

Disclaimer:

OLAS wireless systems are an aid only and should be used alongside existing safety products and procedures. They should not be used for navigation or lifesaving procedures. The OLAS app GPS coordinates cannot be relied upon to be accurate. Whilst accuracy of between 10-30 metres can be achieved, many factors can cause larger variations. The OLAS app cannot and does not take the external environment into consideration. Wind, tide, current and other factors will affect the position of the MOB.

The OLAS app can only assist you in getting back to the position that the automatic alert was issued. The OLAS app is not warranted to be accurate. GPS reception is variable and cannot be relied on. The phone can take up to 40 seconds to get a good GPS lock even when GPS connectivity is available.

The OLAS app will be more accurate if already running for 1 minute before grabbing the GPS location. It is advised that the app is running in the foreground to enable maximum response time. It can take up to 30 second for the system to respond if the phone is in locked mode. The OLAS App should only be used to complement other MOB methods and procedures.

Limitation of Liability:

In no event shall Ultimate Sports Engineering Ltd or its members, representatives or suppliers be liable for any damages whatsoever (including, without limitation, loss of property, personal injury, lost revenue, lost profits, loss of goodwill, business interruption) arising from or related to the use or inability to use or reliance on any OLAS wireless system, even if Ultimate Sports Engineering Ltd or its representatives or agents have been advised of the possibility of such damages. Some jurisdictions prohibit the exclusion or limitation of liability for implied warranties or consequential damages or incidental damages, so the above limitation may not apply to you. You may have other legal rights that vary from jurisdiction to jurisdiction. To the extent any liability is found, in no event will the liability of Ultimate Sports Engineering Ltd, its members, representatives or suppliers exceed the amount paid for the OLAS wireless system inclusive of the OLAS transmitters and receivers.

Patent Notice:

The OLAS wireless systems and associated products may be covered by patents or patent pending applications.

Ultimate Sports Engineering Ltd
Unit 4 Bury Mill Farm
Bury
West Sussex
RH20 1NN
United Kingdom

